



The Village

Almanac

OFFICIAL PUBLICATION OF THE
VILLAGE OF BLOOMINGDALE

Volume 9, Number 2

April, 1984

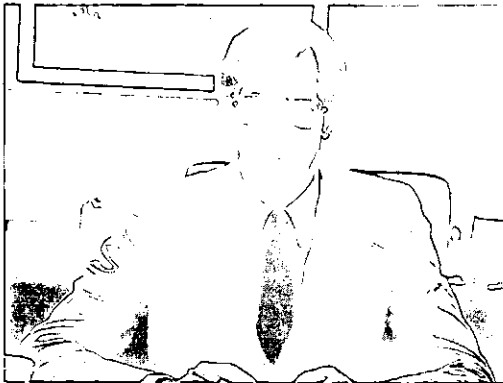

THE MAYOR'S DIRECT LINE

The following is the first in a series of articles by Mayor Samuel J. Tenuto on topics relevant to the residents of Bloomingdale.

HELP US PROTECT YOU

Residential burglary, a "break-in" to your home, is the fastest growing crime in the United States. Burglary is not just a big city crime. Regardless of the neighborhood, whether a private home or an apartment, no dwelling can be considered safe. No door can be left unlocked and no family can be free of concern. It is a dangerous crime, a burglar confronted in your home could mean trouble.

Citizens have tired of living in fear and are looking for ways to protect themselves and their families. There must be closer cooperation between the police and the citizens to effectively combat the increasing crime rate.

Responding to the need to assist people in protecting themselves, the Bloomingdale Police Department has developed a *Neighborhood Watch Program*.

Neighborhood Watch is a program by which citizens watch each others homes and property, reporting suspicious incidents to the police, to help prevent burglaries and other crimes.

The Neighborhood Watch Program is intended to assist our residents by sharing information regarding crime prevention through a network of "block captains". The block captain would maintain a list of names, addresses, and telephone numbers of persons taking part in the program. They would be the liaison between the police and the residents. The captains would encourage the flow of information from neighbors about suspicious circumstances, coordinate home security surveys, and contact new neighbors about the program.

Awareness and involvement are the keys to a successful Neighborhood Watch Program. Residents, properly trained and directed, acting as "extra eyes and ears" for the police, can perform an invaluable service to their community.

Don't make the mistake of thinking burglary will only happen to the other guy.

Continued on Page 3

THE PEOPLE'S CHOICE

At the March 12th Village Board meeting the board adopted an ordinance creating an Aesthetics Committee. The purpose of this committee is to promote awareness for an attractive community appearance of buildings, structures and landscaping in residential, commercial and public areas. It will also set up and administer an Awards Program which will recognize outstanding design and maintenance of residential, commercial and public areas and buildings.

The committee will have five members consisting of one Plan Commission member, one Old Town Commission member, one Chamber of Commerce member and two community group members or citizens. It will be their responsibility to make recommendations to the Village Board on matters pertaining to the aesthetics of Bloomingdale. The committee will meet only a few times during the Fall.

The Village Board is looking for citizens interested in taking part in Bloomingdale's version of the People's Choice Awards for outstanding examples of pride in community appearance. Interested citizens should contact the Almanac through the Village Hall.

Samuel J. Tenuto
VILLAGE PRESIDENT

Marie E. Tayfel
VILLAGE CLERK

Robert F. Reeves
VILLAGE ADMINISTRATOR

TRUSTEES

Biff Behr

Finance & Budget,
Finance Commission, Park District
DuPage Water Commission

Walter Cropper III

Police, Health & Safety, E.S.D.A.,
Police Pension Board

Board of Fire & Plice Commissioners
RTA Services

Joanne Hildt

Old Town/Public Works
Old Town Commission,

Public Relations Committee,
Chamber of Commerce,

Community Development Commission

William Horvath

Public Works,

Regionalization Committee

Robert Iden

Plan Commission, Architectural Review,
Comprehensive Planning Committee,
Cable TV

Sebastian J. "Buzz" Puccio

Zoning, Building & Street Maintenance

Library Board

Suburban O'Hare Commission

VILLAGE BOARD & COMMISSION MEETINGS

*The public is encouraged to attend
all Board & Commission meetings.*

REGULAR MEETINGS OF THE VILLAGE BOARD

2nd and 4th Monday of every Month
7:30 P.M. — Village Hall

COMMITTEE OF THE WHOLE

1st and 4th Monday of every Month
7:30 P.M. — Village Hall

PLAN COMMISSION

1st and 3rd Tuesday of every Month
8:00 P.M. — Village Hall

BOARD OF FIRE AND POLICE COMMISSIONERS

3rd Thursday of Every Month
7:00 P.M. — Village Hall

POLICE PENSION BOARD

Quarterly beginning in January
2nd Monday,
7:00 P.M. — Village Hall

FINANCE COMMISSION

1st and 3rd Wednesday
of every Month
7:30 P.M. — Village Hall

OLD TOWN COMMISSION

3rd Wednesday of every Month
8:00 P.M. — Village Hall

LIBRARY BOARD OF DIRECTORS

3rd Wednesday of every Month
7:30 P.M. — Library

MEACHAM GROVE

The forest Preserve District of Du Page County has, over the years, purchased large areas in the northern part of our Village. These areas lie east and west of Bloomingdale Road and are known as Meacham Grove. Presently, the District is actively working on a restoration program in the eastern section. This program involves the addition of clay fill in the area by the old Krass gravel pit and what used to be a landfill.

The current restoration program was started in 1976, and the District hopes to be completed in 1987. This program is part of an overall master plan for development of this area into useable recreational and open-space, but an implementation schedule is yet to be established. Further information can be obtained through the District at 790-4900.

For persons who are new to the community or for those whose physician may have moved or passed away, Glendale Heights Community Hospital will suggest names of appropriate physicians. The referral number for this free service is 790-6355.

**THE DEADLINE
FOR THE JUNE ISSUE
IS MAY 25**

NO VILLAGE BRANCH PICKUP THIS YEAR

Over the past few years, the Village has picked up branches from May to October. We have found that this service we have been offering is duplicated by Glen Ellyn Disposal, as a part of the normal refuse collection. Therefore, we are reducing our expenses on this program.

According to Glen Ellyn Disposal, their guidelines for branch pickup are:

1. Branches must be bundled in 4-ft. lengths and each bundle should weigh less than 60 lbs.
2. Logs will *not* be picked up. (Your neighbors may want them for firewood.)
3. Phone calls to Glen Ellyn Disposal are not required, but are appreciated. Their telephone is 529-1076.

Should residents need further information, they should contact the Public Works Department at the Village Hall.

Daniel C. Wennerholm, P.E.

VILLAGE ALMANAC
is published bi-monthly by
The Public Relations
Committee of the
Village of Bloomingdale.

Editor,
Mary Ellen Johnson - 351-1503
Production Assistants
Don Lively

Address all correspondence to:
Village of Bloomingdale
Public Relations Committee
201 S. Bloomingdale Road
Bloomingdale, IL 60108
Phone: 893-7000

CABLE UPDATE

THE MAYOR'S DIRECT LINE

Continued from Page 1

At the March 26 Village Board meeting the board agreed to send a letter to Metrovision informing them the Village feels the cable company is in breach of the Franchise Agreement.

Metrovision originally agreed that by January 1, 1984 construction would be completed to the point of allowing activation of the system and offering service to some 4,000 residents. They asked for and were granted an extension to April 1, 1984 to accomplish this. They could not meet this date either.

The Village officials feel the notice of penalties might be the only way to get Metrovision management to take notice that they are not in strict compliance with the terms of the Franchise Agreement, in terms of construction, as well as in other requirements. It is hoped Metrovision will take action in resolving these matters before further action must be taken by the Village.

Statistically, you are as susceptible and as likely a target as the neighbor next to you. Therefore, your involvement in the program is necessary to successfully combat this problem.

If you are interested in becoming a "Block Captain" or participating in the program in any other way, please fill out the form below and mail to:

Chief Gary J. Schira
Bloomingtondale Police Department
201 South Bloomingtondale Road
Bloomingtondale, Illinois 60108

NEIGHBORHOOD WATCH PROGRAM

PLEASE PRINT

NAME: _____ DATE OF BIRTH: _____
(Last) First (MI)

ADDRESS: _____
(Street) (City) (Zip)

PHONE: _____
(HOME)

(WORK)

Best time to contact you: _____

At Which Phone Number: _____



END OF A TRADITION?

At the time of this printing there is no Septemberfest Committee organized to put our annual end-of-the-summer celebration together.

It would be a loss to the community if this event were to be discontinued. Each year has brought more people out to Bloomingtondale to take part in the festivities.

Anyone who is interested in serving on the committee to help keep this tradition alive should fill out the form below and return it to the Almanac editor in care of the Village Hall by May 1, 1984.

Name _____

Address _____

Phone _____

Are you a member of a Bloomingtondale organization? Yes _____ No _____

If yes, which one? _____

No doubt you noticed all of Bloomingtondale seemed to be adorned with beautiful wreaths and garland this holiday season. Bloomingtondale Cub Scout Pack 57 would like to thank all of the families and businesses for their warm support of our wreath sales this year. It was a heartwarming success. We'll look forward to seeing you again next Christmas season!



Anil Gurnaney, sixth grader at Westfield, was the winner of the Sectional Spelling Bee held at Westfield on March 12. Twenty-six schools were represented at the competition.

MAILBOXES

This winter has certainly kept our public works crews busy removing the snow and ice. Hopefully, this is now behind us for several more months. Unfortunately, some of our residents experienced some damage to their mailboxes and posts due to snow removal.

In some cases, mailboxes are insecurely fastened to the post, or the post is weak. When heavy snow and ice is thrown against it, sometimes damage occurs. We cannot be responsible for this, but residents can and should take steps to protect their mailbox from this.

Sometimes, the post is located too close to the street or is leaning and our plow hits it. Since we try to clean all the way to the curb, a few mailboxes may be damaged this way.

Since many residents may not be aware, we have prepared some sketches of how mailboxes should be located. This information was provided by the Post Office. We ask residents to check their mailbox for compliance, and to relocate theirs if necessary. By doing this, and by making sure that the installation is sturdy, homeowners can reduce the likelihood of damage.

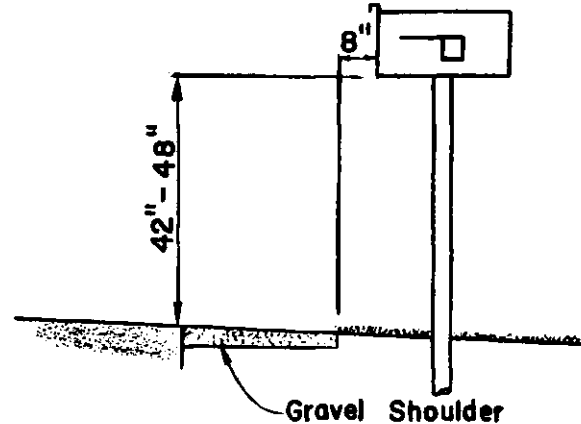
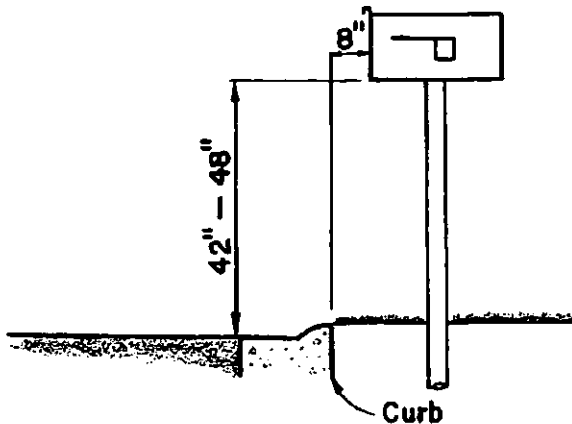

BWC SEEKS ARTISTS

The Bloomingdale Women's Club will be sponsoring its annual Festival of Arts on September 9, 1984. The festival will be on the parking lot of the Bloomingdale State Bank.

The club is currently looking for artists and craftsmen interested in selling their original works. This is an all juried fair with \$100 awarded for Best of Show in both Fine Arts and Crafts. The medias involved in Fine Arts are oil/acrylics, watercolors, glass, photography, jewelry, metals, pottery and multi-media. In Crafts the medias involved are towle (painting or stenciling), wood, ceramics, potpourri, sewing and needlecraft.

Interested artists and craftsmen should contact Lynne 980-5078, Connie 529-0621, Christa 377-1350 or Jan 980-3611. The proceeds from this year's festival will be donated to the Bloomingdale Police Department and the BWC scholarship fund.

LANDMARK FUND

The donations are still coming in for the Landmark planned to commemorate our Sesquicentennial. Every contribution will be part of the legacy and is sincerely appreciated.

The latest donations are:

Harry & Edna Boettger	\$10
Clover Leaf Towers Restaurant	\$200
James C. Dunn & Co., Inc.	\$250
Gail A. Schwartz in memory of her daughter Debra Lynn Plinske	\$200
Margaret M. Swindells	\$100
P.J. Heating & Air Conditioning, Inc.	\$200
Benjamin and Lang Incorporated	\$250

WHAT'S HAPPENING

- April 11** Benefit Flower Show at Glendale Heights Community Hospital. \$3.50 admission. 7:15 P.M. in cafeteria.
- April 14** "My Fair Lady" BWC Fashion Show at Indian Lakes. Tickets \$17.50. Call 980-0892 for more information.
- April 25** Bloomingdale swim team parents meeting at Park District. 7:30 P.M. Call 529-3650 for details.
- May 17** Bloomingdale Blood Association Blood Drive at DuJardin School. 4 - 8 P.M. Call 529-5177 for more information.
- May 19** Mini "500" Big Wheel Race for ages three to six. Register now through day of race at Park District.

SPOTLIGHT

When you ask Trustee Biff Behr why he ran for the office of trustee, you can detect a twinkle in his eyes as he explains he wants to be mayor someday and figures this is a good stepping stone. Whether he is serious or not, (and we suspect he isn't) the fact remains that Behr doesn't fit the mold of a politician. And that, in itself, is refreshing.

In everyday life Biff is the president of Behr & Co., a local C.P.A. firm specializing in personal, professional and corporate financial planning. The firm handles tax return preparation and represents clients, if necessary, in front of the I.R.S., as well as analyzing business and individual investments and transactions to determine long-term tax and financial impact. It also develops long-term financial plans for families.

Behr's many affiliations speak to his success in his field. He is a director on the board of one of the operating banks in First Oak Brook Bancshares and a vice president and director of NRS, Inc., a company specializing in computerized accounting systems. He is also vice president and director of AUTCO, Inc., a company specializing in support services for the automobile industry.

It is this varied experience and expertise he brings to the Village serving on the DuPage Water Commission and as chairman of the Village's Finance Commission. On one hand Behr will interrupt the Village Board's progress with probing questions revealing his insight into the magnitude of the process, while on the other hand, his sometimes flippant comments serve to remind all present, we are, after all, only human.

When he seriously answers the question of why he sought public office, Behr acknowledges the posi-

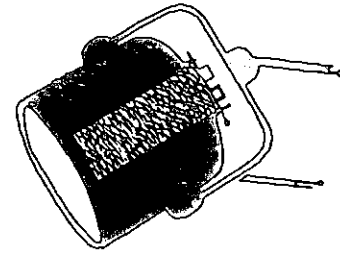

tion is a challenge for him and affords him an opportunity to draw on his professional and technical expertise. But he too, as do most of the trustees, expresses a dislike for all the red tape that stands in the way of accomplishing a goal or solving a problem. He does like the fact that he has the opportunity to work with a variety of people who offer him a chance to learn new information or to expand on prior knowledge.

Trustee Behr brings a constant enthusiasm to his position, you get the feeling that he is sincerely concerned about the Village and its residents. He was attracted to Bloomingdale in 1976 because of its long history providing greater stability. "Yet, at the same time," he says "it seemed to be an area experiencing tremendous growth. It was this combination of stability, with a fresh outlook, which appealed to me then and now."

Biff is also very enthusiastic about his hobby - the restoration and collection of antique automobiles. He is a member of the Auburn/Cord/Duesenberg Club and one of the founders of the Great Lakes Region Vintage Chevrolet Club of America. Many of the vehicles he has restored are on display at museums throughout the United States. Biff is especially proud of his three cars on permanent display at Disney's EP-COT Center in Florida.

After allowing a glimpse at the sedate side of Biff Behr he can't resist adding, "When not working, or at a Village meeting or under a car, I can generally be found eating dinner at Rosati's or Carlos Sweeney's, or at Killshot looking for someone who plays racquetball as badly as I do, or at Nautilus wishing I was younger." Now where can you find another politician who would admit to that last part in print?

WEST SUBURBAN BANK
of Carol Stream / Stratford Square
401 North Gary Avenue, Carol Stream, IL 60188 (312) 690-8700
 335 West Army Trail Road, Bloomingdale, IL 60108 (312) 351-0800

Serving DuPage County 7 days a week

HOURS	DRIVE-UP	LOBBY
Mon.-Wed.	6:45 a.m.-7:00 p.m.	9:00 a.m.-5:00 p.m.
Thurs.-Fri.	6:45 a.m.-8:00 p.m.	9:00 a.m.-7:00 p.m.
Saturday	6:45 a.m.-5:00 p.m.	9:00 a.m.-1:00 p.m.
Sunday	10:00 a.m.-2:00 p.m.	Closed



Where Strength is Matched by Service

MEMBER
FDIC

LIONS HALF-A-THON

The Bloomingdale Lions Club annual Half-a-thon is scheduled for June 9, 1984 to begin at 8:30 A.M. The Lions began the Half-a-thon in 1978 as a community service to promote physical fitness in the community. The race has grown so quickly in the past few years that it has become a major run in the area. The club is expecting anywhere from 1200 to 1500 runners this year.

Springbrook Shopping Center and Indian Lakes Resort are co-sponsoring the event both committing strong financial support. The Lions also have three national companies as secondary sponsors - Anheiser Busch, Converse and Canfield's.

From the run the Lions have designated a minimum of \$5000 to the research, treatment and eventual cure of diabetes, which is, with its complications, one of the leading causes of death. Lions throughout the world have accepted the challenge to fight this terrible disease.

The Guardsmen Cadets Drum and Bugle Corps from Schaumburg will be entertaining during the race, starting at 7:30 A.M. at Indian Lakes, then marching to Springbrook Shopping Center and playing there

until 11:30 A.M. A number of Bloomingdale children are part of this group. Also at Springbrook complimentary Canfield's beverages will be served to both runners and spectators during the race.



Mr. Richard Weber, general manager of Indian Lakes Resort, presents a check for \$5000 to Lion Jim Krause, race director and in-coming Lion President Jim Robertson for the June 9th Half-a-thon.

The Lions Club needs volunteers to help on the day of the race, especially monitors and in the aid stations. Anyone interested in lending their support should be at Westfield School at 7:30 A.M. the day of the race.

Applications to run can be picked up at West Suburban Bank of Carol Stream/Stratford Square or at most Springbrook stores. For more information or to have an application mailed out, call the bank at 351-0600.



"We've been peddlin' since 1958"

*The Most Unique Family Owned
and Operated Business in Town.*

Econ-O-Mart

110 SOUTH RIDGE
BLOOMINGDALE, ILLINOIS 60108

529-5490

HOURS:
Mon., Tues., Thurs. 9-6 Sat. 9-6 - Sun. 12-6
Fri. 9-9 Closed Wed.

**Celebrating Our 26th Year of Service
to Bloomingdale**

GET SET FOR SUMMER

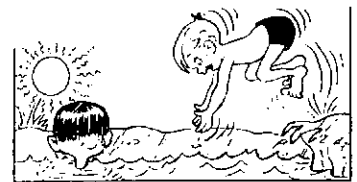

With the arrival of spring, families begin to ask the question: What will the children do this summer? One way to answer it is by browsing at the library. *Peterson's Summer Opportunities for Kids and Teenagers* lists a vast array of recreational and educational programs in addition to traditional summer camps. For instance, specialized training programs are offered in art, drama, nature study, sports, and computer science. Summer employment opportunities for students through college age are included.

Another directory is the *Parents' Guide to Accredited Camps*. It includes advice on preparing your child for camp, questions to ask a Camp Director, and budgeting for camp.

For students, teachers, or others looking for summer jobs, the *Summer Employment Directory of the United States* may be helpful. It offers chapters on finding a job in your home town and polishing job hunting skills. It lists job opportunities at camps, parks and resorts nationwide.

Worship with us... **HOLY WEEK SERVICES**

PALM SUNDAY

April 15th - 10:00 A.M. Blessing of the Palms & Procession
Holy Eucharist

MAUNDY THURSDAY

April 19th - 7:30 P.M. Holy Eucharist - Stripping of the Altar

GOOD FRIDAY

April 20th - 7:30 P.M. Good Friday Liturgy

EASTER SUNDAY

April 22nd - 10:00 A.M. Festive Eucharistic Celebration
Plants for the Children
Incarnation Choir
Accompanied by String Quartet



**EPISCOPAL CHURCH
of the
INCARNATION**

MEETING AT CENTRAL SCHOOL • BLOOMINGDALE

351-3249

(One Block West of Old Town)

NEW BUSINESS IN BLOOMINGDALE

This issue will introduce you to two new businesses. Video Biz will bring Mickey Mouse and Rocky into your living room. The second new business, The Cove, is an example of how a hobby can turn into a successful business.

VIDEO BIZ - Located in Old Town Square at 160 South Bloomingdale Road, Video Biz is owned and managed by Greg Urban.

After searching for the right location, Greg chose Bloomingdale to start his first business because of the friendliness of the residents. Video Biz offers a wide selection of both Beta and VHS format video tapes. Drama, children's fare, comedy, action, and the latest releases are all here.

Being a part of the Video Biz franchise, Greg is able to get and maintain a wide selection of subjects. Memberships are offered and honored at all stores. Right now there are six stores, but there will be 15 by this summer.

There are three types of memberships: 6 month, 1 year and lifetime. Each offers special discounts, free tapes and newsletters on coming offers. Even if you are not a member, you can find your favorite movie available for purchase or rent at reasonable prices.

If you don't already own a video cassette recorder, Greg will help you select a machine to purchase or rent from his wide selection of VCR's. The next time you want something special for a party or low cost entertainment for you and the kids, drop by Video Biz and Greg will help you find just what you're looking for.

THE COVE - Located at 109 S. Third Street in Cody's Hotel, The Cove is the browser's delight. The shop's owners, the Bert, Stein and Wagner families, all agree that Bloomingdale's Old Town is the perfect place for their shop.

Specializing in collector plates and figurines, the Cove is a Hummel and Anri Redemption Center, a Bradford Exchange dealer and a member of N.A.L.E.D.

The owners have literally lived with their business; collecting Hummels as a hobby was the starting point for the Wagners. Over the years their desire to find special and unique Hummels led them not only to shows all over the United States, but even to the workshop in Germany. Here they saw how each figurine is handcrafted and painted by expert hands.

Hummels were first created in the early 1930's. Servicemen during WWII helped introduce the figurines to this country by sending them home as gifts from Europe. Today 90 per cent of the Hummels produced are sold in the United States.

Although many pieces increase in value over the years, Ray Wagner suggests you should always buy what you like, not necessarily what you think will grow in value. In this way each piece becomes part of you or part of the family, as happened with his collection. The same holds true for collector plates, he says. Two of the several series available are *Norman Rockwell* and *Gone With the Wind*.

Whether you are an avid collector or just a beginner you will be impressed with how knowledgeable and helpful the people at the Cove are when it comes to helping you select just the right item.

TEN YEAR VOLUNTEER

Patricia Cropper was reappointed to the Police Pension Board on Nov. 14, 1982. Cropper, who has been on the Police Pension Board since its inception has now become Bloomingdale's longest term commissioner with ten years of service.

During the appointment ceremony Mayor Samuel Tenuto stated, "Pat, you have provided our community with a valuable service by unselfishly giving of your time and expertise to insure that our Police Officers Pension Fund is professionally administered." Bloomingdale Police Chief Gary Schira says, "Pat is a very caring conscientious person whose sincere involvement makes her a valuable member of the board."

Former Mayor Bob Homola saw all of these qualities ten years ago when Pat worked in his campaign for mayor. After his election Bob asked Pat to serve on the Police Pension Board. When asked why she has continued on the board for all these years, Pat simply states, "I enjoy the work and enjoy working with the officers."

The five person Police Pension Board's primary function is to invest funds so that the officers receive the maximum return on the money invested. There are guidelines as to what types of investments can be used, but the actual selection is made by the board. The money for this fund comes from contributions made by both the officers themselves and the Village. Another function of the board is to evaluate disability claims.

**"Compare with me...
Before you pay your next
Auto or Homeowners Premium"**

LARRY BEEMAN
529-0114

107 S. Bloomingdale Rd.
Bloomingdale, IL
60108

State Farm Insurance Companies
Home Offices: Bloomington, Illinois



**FREE ROAD
ATLAS**



State Farm
Road Atlas

**STOP IN WITH YOUR PRESENT POLICY
PICK UP YOUR COMPUTER QUOTATION AND FREE ATLAS.**

CHILDREN'S CORNER



Look at Your Library

Art work loaned by the students of DuJardin School is now on display in the Children's Department. Very soon Central School will share wonderful things with us.

Come and see what you have done... Look at the ROUND showcase and enjoy the collections and creations of your friends... Add to the suggestion area... Try some of the 20 magazines that are ordered just for you, and READ A BOOK THIS WEEK.

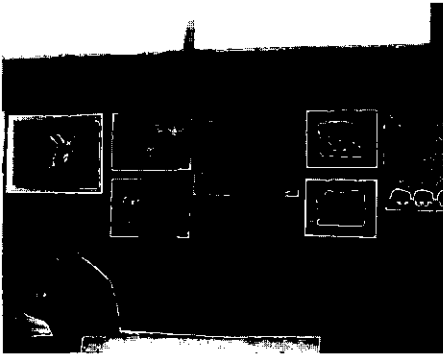

DuJardin artwork on display.

NEWSWORTHY NOTES

LOCAL WOMAN WINS TOP AWARD

Applause... spotlights... fanfare... recognition. Resident Eileen Sciackitano received all this and more as she was named one of the top sales directors at the Mary Kay Cosmetics 20th Anniversary Diamond Seminar held last fall at the Dallas Convention Center.



Eileen Sciackitano

Sciackitano, an independent sales director with the Dallas-based cosmetics firm, was greeted on stage by company founder and chairman Mary Kay Ash who personally congratulated her for leading her sales unit of independent beauty consultants to exceed retail sales of \$300,000 during the previous year.

For her outstanding leadership ability, Sciackitano received a spectacular 14k gold bar pin displaying her unit's retail achievement in diamonds.

RONALD J. SMAGA graduated from Loyola University of Chicago in January with a master's degree in business administration. The three-year resident was supported in his efforts by his wife Jane and two children.

Smaga received his bachelor's degree in accounting and business management from Augusta College. He is currently a controller with GTE Network Systems in Genoa.

DONALD R. GEHRICH has been named central regional sales manager for Casa Di Bertachhi Corp., a Vineland, N.J. - based Italian frozen food processor. Gehrich, who attended Indiana University, will be responsible for sales in the Midwest markets.

He is an active Bloomingdale Lion, as well as being involved in the Grocery Manufacturers Sales Executives and the Merchandising Executive Club.

ROBERT C. MAGUIRE, supervisor of pure water in Bloomingdale, was recently elected chairman of the Mid Central Waterworks Association. The organization which has 140 members, has been in existence since 1956. Its main function is to provide an exchange of ideas and information for suburban area water superintendents, water personnel, utilities and waterworks suppliers.

Maguire has been a member for five years and had held an office for the last three. He has been with Bloomingdale for five and a half years.



George Thies III, pharmacist at Bloomingdale Pharmacy spoke to area youngsters about the dangers of poison during Poison Prevention Week last month. Here he is with kindergarteners at DuJardin.

<h1>OLD TOWN BLOOMINGDALE</h1>	
<p>A Turn of the Century Shopping Experience.</p>	
<p>Lake Street (Hwy. 20) at Bloomingdale/Roselle Rd. Bloomingdale, IL (312) 980-0327</p>	
<p>Hours: Tuesday - Saturday 10-5 Sundays 12-5 Thursday til 8:30pm</p>	

DISTRICT 13 NEWS

by Karen Gerovac,
Board of Education President

March was Youth Art Month in Illinois, and also Music in Our Schools Month. Students in our district have taken a very active part in demonstrating their interest and aptitude in these areas.

Seventh-grade art students at Westfield judged and selected plaster sculptures with an olympic theme by their classmates to be displayed at the Roselle Library. DuJardin students chose a jungle fantasy theme for display at the Bloomingdale Public Library. Central students hosted their parents at evening sessions throughout the month, where they created original works of art for the home. Art in our schools is directed by Renee Cherrie at Central, Carmen Parrilli at DuJardin, and Marge Bristow at Westfield.

Rodger Himmel directs instrumental music in our district. The solo contest in March brought many first place ratings to his students, and the Westfield Jazz Band took first-place honors at Mundelein Jazz Fest.

Our students have distinguished themselves in academic areas as well. Anil Gurnaney, Westfield's entrant in the sectional spelling bee, took top honors at that meet and went on to represent Westfield at the county meet. Central's top speller was Patrick Lee, with Rachel Pope taking top honors at DuJardin.

Westfield's mathematics students took part in two competitions, one sponsored by the Illinois Mathematics League, and the other sponsored by Westfield for all students. Winners in local contests will go to compete at Lake Park and at the state level.

DuJardin's annual science fair brought many blue, red, yellow and white ribbons to students. Exhibits ranged from studies of molds in foods to solar system to space ships.

Young writers at Central and DuJardin saw some of their efforts acted out in assemblies at their schools. Rachelle Scheller and Brad Jones from DuJardin, and Jimmy Hanlon, Michele Sajdak and Nikki Darch took the honors. Certificates of Creativity were presented to 18 additional students at Central, and 17 at DuJardin.

Bloomingdale's second annual Student Government Day will be coming up on Friday, May 4. Michael Zivic, Assistant Principal at Westfield, will be directing the contest, which will select students to fill the shoes of village officials for the day.

And some competitions are just for fun in our schools. Central's recent study of the Olympics culminated in a fun evening of mock olympic events. Each of our schools will hold a field day in the spring.

The school year is rapidly drawing to a close, and next year's calendar has been drawn up. Important dates include:

August 28	School Begins
December 24	Winter vacation
January 4	
April 5-12	Spring Vacation
June 10	School Closes



BARRACUDA SEARCH

The Bloomingdale Barracudas, the Park District Swim Team, is looking for swimmers under the age of 18. In order to be eligible for the team you must be able to swim the length of the pool.

A parents' meeting will be held April 25 at 7:30 P.M. at the Park District, 172 S. Circle Avenue. Coaches will be present and will explain the swim program. For more information call the Park District at 529-3650.

RE/MAX
REALTORS®

160 S. Bloomingdale Rd.
Bloomingdale, IL 60108

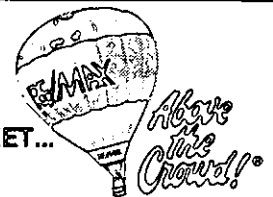

**IF YOU'RE IN THE HOUSING MARKET...
HERE'S HOW I CAN HELP!!**

- **FREE Buyer Counseling**
- **FREE Market Evaluations**
- **Professional, aggressive marketing of your present home.**
- **Extensive, financing knowledge to benefit buyers and sellers.**

DEDICATED SERVICE!! GUIDO SCHULTE 893-7860

NEWS FROM THE CHAMBER

The Bloomingdale Chamber of Commerce is now in its third year. Each year brings more members, more programs and a stronger force for the business community.

Elections for the 1984 officers and directors were held recently. President is Ed Levato, Attorney at Law; vice president Jim Luberd, All-Pro Exterminators; secretary Ken Murphy, Kenneth R. Murphy & Associates; treasurer Dale Doepke, Bloomingdale State Bank. The directors for the Chamber are: William Beutin, Advanced Systems Applications; Robert Merollo, Chicago Metro Alarm, Inc.; Rae Novak, Westlake Graphics; Paul Paoletti, Paul Paoletti, Ltd.; Donna Rubino, Western DuPage Secretarial Service; Gary Schira, Bloomingdale Police Department; Mike Springer, Information Resource Management.

The Chamber's next luncheon meeting will be held on April 19 at Houlihan's. Open bar begins at 11:30 A.M. with lunch beginning at noon. The topic will be "The Business Person and Police Cooperation - Problems Facing Both of Us." The presentation will be made by Police Chief Gary Schira. For reservations call 980-9340.

Other upcoming events include participation in a Student Business/Government Day during April and the annual Golf Outing on June 21. Tee off time is 8 A.M. at Indian Lakes. This year a \$10,000 prize is being offered by Carlos Sweeney's for a Hole-in-One. Tickets for the golf outing are \$40. For reservations or more information call 980-9340.

People are dying for your help.

Give blood.

WON'T YOU HELP

The Bloomingdale Blood Association has been serving the community for 13 years. The Association is comprised of caring individuals who donate their time to safeguard the needs of the community. Approximately four meetings and three blood drives are held each year.

In order for us to continue to serve the community effectively, we need additional volunteers to assist us in our work. Since every resident of Bloomingdale is covered by the blood program, we are asking each resident to consider giving a little of their time. You will have the satisfaction of knowing that blood will always be available for you and your family as well as providing a service to the community.

Our next drive is scheduled for Thursday, May 17 at DuJardin School on Euclid Avenue from 4-8:00 p.m.

We invite you to join us in this life saving program. If you can help us in any way, please call Bonnie Sassman at 529-5177 or Lee Beckermann at 980-6520.

BLOOMINGDALE STATE BANK

3 Convenient Locations

13 Drive-In Lanes

24 Hour Banking

"We have a daily interest in you"



BLOOMINGDALE STATE BANK

114-118 East Lake Street • Bloomingdale, Illinois 60108

Phone 980-2200

GLENDAL HEIGHTS BANKING CENTER

310 East Army Trail Road

Glendale Heights, Illinois 60137

SPRINGBROOK BANKING CENTER

136 East Lake Street

Bloomington, Illinois 60108

Member FDIC

“WHAT DO YOU THINK?”

A TEAM EFFORT

The following letter was received by Mayor Tenuto. We'd like to share it with you.

On the morning of Sunday, January 29, I noticed a foul odor coming from my basement. I attempted to correct this, but after several hours decided it was futile.

I therefore contacted the Police Department and told the woman who answered that I thought I had sewer gas coming into my house. This was around 12:35 p.m. The woman said she would see if she could contact someone. *Not more than 10 minutes later* I received a call from a person from, I believe, the Streets and Sanitation Department who asked several questions and said he would check out the sewer line that runs behind my home. *Not more than 30 minutes later* a person came to my house and informed me there was a backup in the sewer line and that he would get it cleared up as soon as possible. *No more than 1½ hours*

later I noticed a Village of Bloomingdale crew working to clear the sewer line. They must have been successful as the foul odor dissipated in a few hours.

Unfortunately, I didn't get the names of the Police Department woman, the Streets & Sanitation man, nor the crew. I obviously appreciate the efficient handling of the problem and believe credit should be given to these people for their quick response. I would appreciate it if you would pass along my thanks to the people involved. You might call the resolution... the sweet (non) smell of success.

Barry M. Cornwell

The Village employees Mr. Cornwell spoke of are Jan Cox of the Police Department, Tim Helfron and Bob Roberts, both of the Wastewater Treatment Department. In his comments to these people for their outstanding teamwork Mayor Tenuto said, "It is especially gratifying to me to know that you are very responsive to our resident's problem no matter what time or day it is."

T TIPST
from the
Building Inspector

For fast, efficient service from your Building Department when applying for a building permit, make sure you meet all the informational requirements requested by the department's preapplication procedures, which are supplied upon request.

893-7000 Ext. 29

Member of:

Copyright 1976 by Building Officials and Code Administrators International, Inc.

OPINION FEATURE

Please tell us if you have any suggestions or questions for your Village. What you think is important to us. Write your thoughts below, then detach and mail to "What Do You Think," Village of Bloomingdale, 201 S. Bloomingdale Rd., Bloomingdale, IL 60108. No unsigned submissions will be considered. The ALMANAC reserves the right to reprint all or part of the submission depending upon length. We do, however, try to retain the gist of the query.

My thoughts are as follows: _____

Name _____ Address _____

Print my name: Yes _____ No _____

BLOOMINGDALE BUSINESS DIRECTORY



Village of Bloomingdale
201 S. BLOOMINGDALE ROAD
BLOOMINGDALE, ILLINOIS 60108

BULK RATE
U.S. POSTAGE
PAID
Bloomingdale, IL
60108
Permit No. 16

ACCOUNTANTS

Schoen, Coyle & Co.
Certified Public Accountants
125 S. Bloomingdale Road
980-4121

ALARMS

Chicago Metro Alarm, Inc.
Residential - Commercial - Industrial
117 W. Lake Street 894-4700
Burglar • Fire Alarm • Medical Alert

CARPET CLEANER

Broom Brigade, Inc. 894-4666
Commercial & Residential Cleaning
Carpet • Upholstery • Walls • Windows
Furniture Touch-up & Repair

CARPET CLEANER

Sansone Carpet, Drapery
and Upholstery Cleaners
312 Edgewater Drive
893-4010

CHIROPRACTOR

Bloomingdale Chiropractic Clinic
Dr. James Dean
181 S. Bloomingdale Rd.
980-5460

CHIROPRACTOR

Keller Chiropractic Clinic
220 E. Lake Street
980-6555 Hours by Appointment
Total Health Care Facility

DENTIST

Frank D. Letizia D.D.S.
Clover Leaf Towers Suite 309
201 E. Army Trail Road 529-0303
Family Dentistry

DENTIST

William J. McElroy, D.D.S.
183 S. Bloomingdale Rd., Suite 105
351-4440
Children's & Hospital Dentistry

DENTIST

Robert Meyers, D.D.S.
135 First Street
893-4650
Office Hours by Appointment

DENTIST

James Paradowski, D.D.S.
255 E. Lake Street
529-7130
Office Hours by Appointment

GENERAL MERCHANDISE

Econ-O-Mart
110 Ridge Road
529-5490
You're invited to browse and save.

HARDWARE

Warnimont's True Value Hardware
23 W 745 Lake Street
529-3030
Comm. Edison Bulb Service

HOUSECLEANING

The Bucket Brigade
289-9733
"Reliable, Personal Homecare"
Free Estimates

INCOME TAX SERVICE

Behr & Co.
Certified Public Accountants
Tax & Financial Planners
247 Lakeshore Lane 351-0003

INVESTMENTS

IDS/American Express Inc.
Investors Diversified Services
Dorothy J. Lingeman
359-3220 or 529-0858

JEWELER

Lustig Jewelers Since 1949
Stratford Square Mall Upper Level
351-8900 Diamond Setting • Engraving •
Custom Jewelry • Watch & Jewelry Repair

MONOGRAMMING

Yours, Mine & Ours
273 Oxford Lane
980-9323 Prompt Service
20% Discount With This Ad

NURSING HOME

Applewood Manor Convalescent Center
275 Army Trail Road
893-9616
"Let our family help yours"

NURSING HOME

Bloomingdale Pavilion Nursing Home
311 Edgewater Drive 894-7400
Retirement • Convalescence • Restorative
Nursing • Rehabilitation • Intensive care

POSTAL PATRON, LOCAL
BLOOMINGDALE, ILLINOIS 60108

OBSTETRICIAN and GYNECOLOGIST

Dr. (Mrs.) Malathi Seshadri
Clover Leaf Towers Suite 307
201 E. Army Trail Road 980-7545
24-hour Answering Service

OFFICE MACHINES AND COMPUTER FURNITURE

Sales - Service - Rentals - Supplies
Call for demo - Your office or ours
BMK Associates 980-9396
109 Fairfield Way Suite 105

PERIODONTIST

Stanley E. Treitler D.D.S.
130 N. Bloomingdale Road
893-7979
Practice Limited To Periodontics

PHARMACY

Bloomingdale Pharmacy
Bloomingdale & Schick Roads
980-9198 or 980-9199
Free Prescription Delivery

PHOTOGRAPHERS

Art Craft Photographers
First Street & Schick Road
529-8400
Weddings • Portraits • Invitations

PRINTING

Budde's Print Shop
159 West Lake Street
894-4009
Let Us Make You Look Good In Print

PROFESSIONAL PHOTOGRAPHY

Portraits - Model - Family - Advertising
Studio • Home • Outdoors
Inexpensive, Prompt, Personal Service
980-1316 20% Discount With This Ad

SECRETARIAL SERVICE

Western DuPage Secretarial Service Inc.
109 Fairfield Way — Suite 106
893-9340
Exec. Typing & Word Processing Service

VETERINARIANS

Bloomingdale Animal Hospital
Drs. Borman, Olson & Page
290 Glen Ellyn Road
893-4330

**KEEP YOUR TAX DOLLARS
WORKING FOR YOU!
BUY IN BLOOMINGDALE!**